

Horizontal Container Pump Lutz B200

Container Emptying: The compact solution

For optimum transfer of thin-bodied,
light or low viscous liquids



New: SafetyBox for
leakage detection



New: Now
available in
PVDF



Safety is our concern

Horizontal Container Pump Lutz B200

Different materials for a wide range of applications

This very compact pump is an interesting alternative when conventional vertical drum pumps cannot be used e.g. for containers which are stored in shelves.

In these cases an access from above is not possible, but the bottom drain of the IBC can be used. For this purpose the new horizontal Lutz B200 is directly connected to the bottom outlet valve. The hydraulic capacity is much higher compared to a hydrostatic outlet.

In combination with delivery hose and nozzle, this pump allows a controlled filling and also can be operated against a closed valve.

Product Features:

- » Centrifugal pump with axial impeller in compact design, **low space requirement**
- » Directly connected to the bottom outlet valve of the IBC with standard union nut (S60 x 6)
- » **Variable drive concept**
(compatible with all universal and compressed air motors)
- » **Easy to dismantle**, two-part pump with clamp connections according to DIN 32676 (stainless steel version)
- » **No suction hose required**, therefore significantly lower product release during disconnection
- » **Explosion-proof** stainless steel versions for applications in Ex-areas (Zone 1 and 2), including check valve
- » Significantly **better hydraulic capacity** compared to hydrostatic outlet
- » Operation against closed shutoff elements (e.g. ball valve, nozzle) is possible at any time
- » **The new PVDF version** for highly aggressive liquids
- » Optionally with **SafetyBox for leakage detection**



Lutz B200 PVDF



Lutz B200 SS in food version



Lutz B200 SS in explosion-proof version



See the
video now!

Horizontal Container Pump Lutz B200

Pump Capacities:

Similar to the conventional Lutz drum and container pumps, the new pump tube can be combined with various universal and compressed air motors¹. This results in different pump capacities.

¹ Motors see main catalogue.

Typical liquids being pumped

- » Thin-bodied mineral oil products
- » Emulsions
- » Solvents
- » Aqueous solutions
- » For highly aggressive alkalis and acids
- » Vegetable oils
- » Cleaning, care and disinfection agents



Horizontal Container Pump Lutz B200

Pump tube PVDF

Technical data:

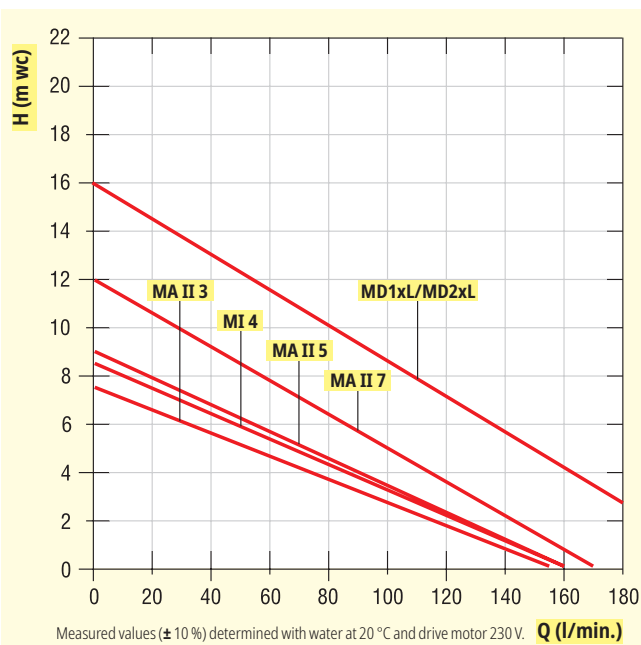

Flow rate:	max. up to 216 l/min
Delivery head:	max. up to 16 m wc
Viscosity:	max. up to 1000 mPas
Density:	max. up to 2.8 kg/dm ³
Temperature:	max. up to 100 °C
Weight:	650 g
Materials:	PVDF, Hastelloy-C, FPM, Carbon, SIC, PTFE, ETFE

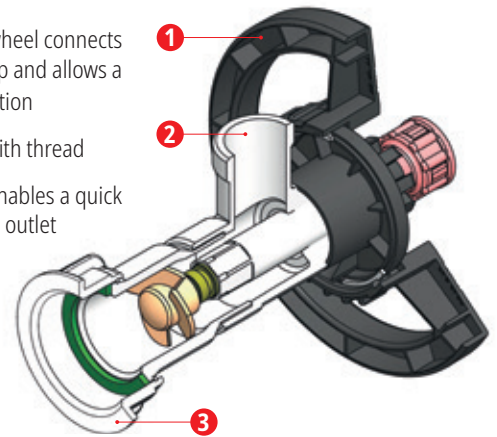

- 1 The Lutz hand wheel connects motor and pump and allows a quick disconnection
- 2 Pressure joint with thread
- 3 The union nut enables a quick mounting at the outlet of the container



Recommended accessories:

Ref.-No.	Description	
0208-193	Turnbuckle Relieves the outrun piece when using heavy motors	
0208-192	Mounting bracket Relieves the outrun piece when using heavy motors, if turnbuckle cannot be used	

For the container pump Lutz B200 PVDF the following sets/versions are available

Comprises of:	Pump tube Lutz B200 PVDF	Set Lutz B200 PVDF conc. acids and alkalis	Pump tube Lutz B200 PVDF with SafetyBox*	Set Lutz B200 PVDF conc. acids and alkalis with SafetyBox*
Pump tube B200 PVDF 41-R-MS	✓	✓	✓	✓
2 m special chemical hose DN 19 with PVDF connection	-	✓	-	✓
Nozzle PVDF	-	✓	-	✓
Monitoring module SafetyBox	-	-	✓	✓
5 m power supply cable, 230 V	-	-	✓	✓
Ref.-No.	0123-420	0205-291	0205-290	0205-292
Ref.-No. Additional price seal kit FFPM/PE	0123-110			

*Use motors with low-voltage release, see main catalogue.

Horizontal Container Pump Lutz B200

Pump tube SS

Technical data:

Flow rate:	max. up to 244 l/min
Delivery head:	max. up to 15 m wc
Viscosity:	max. up to 1000 mPas
Density:	max. up to 2.8 kg/dm ³
Temperature:	max. up to 100 °C
Weight:	1.5 kg
Materials:	Stainless steel 1.4571, ETFE, PTFE Carbon, ceramic, FPM or EPDM

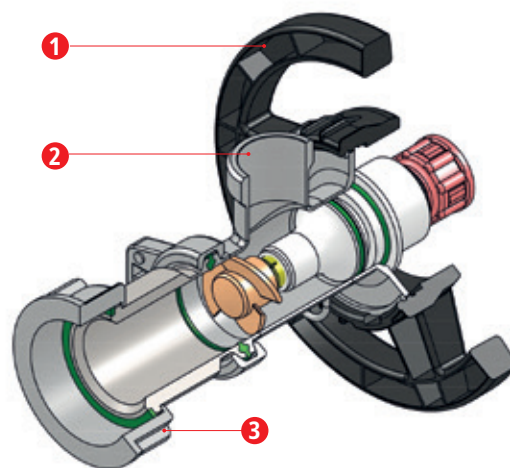
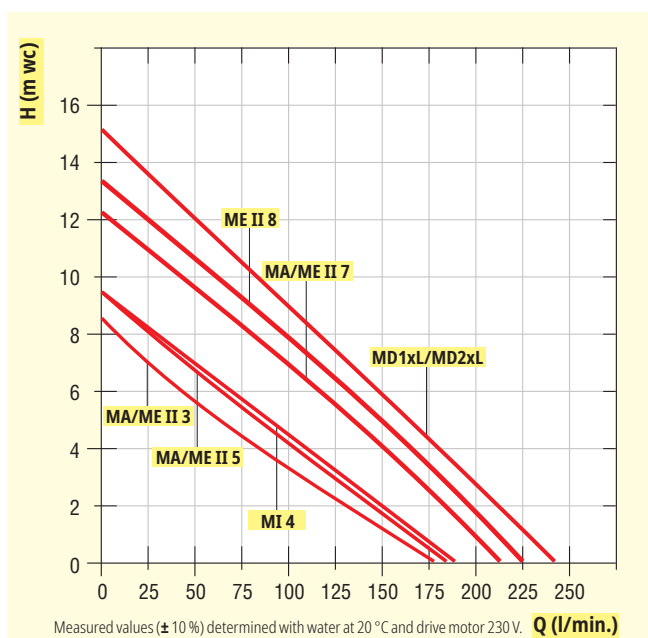

- 1 The Lutz hand wheel connects motor and pump and allows a quick disconnection
- 2 Pressure joint with thread or clamp connection
- 3 The union nut enables a quick mounting at the outlet of the container











Several pump tubes are available for container pump Lutz B200 SS:

Ref.-No.	Description	
0151-400*	Pump Tube B200 SS 41-R-MS FPM, OT 1 1/4"	
0151-401*	Pump Tube B200 PURE SS 41-R-MS FPM, Clamp DN 32	
0151-402*	Pump Tube B200 PURE SS 41-R-MS EPDM, Clamp DN 32	
0151-403*	Pump Tube B200 Ex PURE SS 41-R-MS FPM, Clamp DN 32	
0151-404*	Pump Tube B200 Ex PURE SS 41-R-MS EPDM, Clamp DN 32	

*Version is not available in Japan

Range of accessories

Pump tubes B200

Product detail	Specification	Order No.
	Adapter fitting Tri-Clamp (1.4404) DN 32 / G 1 1/4 OT	for B200 SS 0370-104
	Tri-Clamp locking clamp (1.4404), DN 25/32/40	for B200 SS 0370-088
	Tri-Clamp seal EPDM DN 32 FPM DN 32	for B200 SS for B200 SS 0314-596 0314-597
	Check valves SS FPM Clamp DN 32 EPDM Clamp DN 32	for B200 SS for B200 SS 0208-202 0208-203
	Mounting bracket B200 Relieves the outrun piece when using heavy motors, if turnbuckle cannot be used	0208-192
	Turnbuckle Relieves the outrun piece when using heavy motors	0208-193
	Wing nut for outrun piece Stainless steel, thread S60 x 6, seal FPM Stainless steel, thread S60 x 6, seal EPDM PVDF, thread S60 x 6	for B200 SS for B200 SS for B200 PVDF 0151-427 0151-428 0123-108
	Electronic flow meter, TR3-PVDF series For efficient flow rate measuring of various liquids. Ease of handling, compact design, connection G 1 1/4 Material polyvinylidene flouride (PVDF) For more details see flow meter brochure.	
	Hose connections See accessories drum pump brochure	
	Hoses See accessories drum pump brochure	
	Nozzles See accessories drum pump brochure	

Horizontal Container Pump Lutz B200

Monitoring module SafetyBox for container pump B200 PVDF

Dynamic seals are subject to wear and can lead to leakage

The consequences are:

- Environmental contamination
- Health risk

Dynamic seals should be replaced after specified operating times. Since the operating time of mobile pumps is less easy to monitor, there is a higher probability that wearing parts will be used longer than expected. The solution is the SafetyBox monitoring module with which leaks in the mechanical seal can be detected.

Benefits:

- » Safe operation
- » Low cost solution
- » Simple installation, can be retrofitted at any time
- » Can also be used for other Lutz drumpumps

Function:

- » **Detects leakage** of conductive liquids
- » **Visual and acoustic signals for leakage detection** (siren, lamp)
- » **Emergency stop function** of the motor in case of leakage
- » **Plug & Play**
- » **Easy installation** by attaching a leakage sensor to the connecting head of the pump

Technical data SafetyBox:

Voltage:	230 V
Frequency:	50 Hz
Max. switching current:	8 A
Type of protection:	IP 54
Ambient temperature:	10-50 °C
Weight:	1050 g
Minimum conductivity of the detectable liquid:	10 µS/cm
Sensitivity adjustment range:	5-100 kΩ

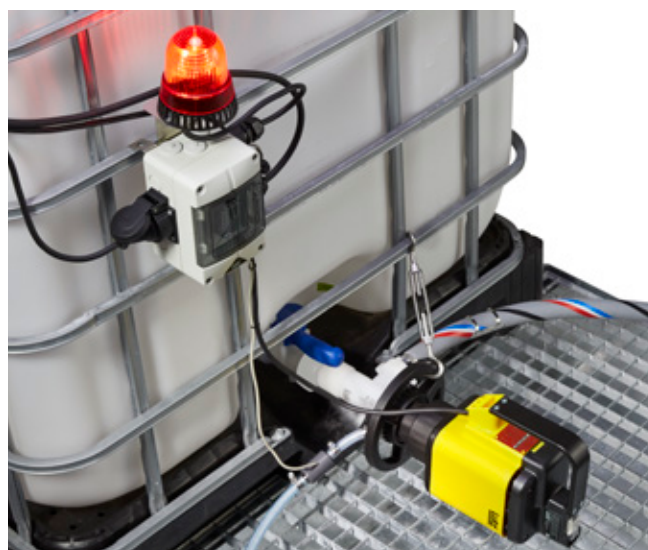

SafetyBox for container pump Lutz B200 PVDF

Ref.-No.	Description
0208-450	Monitoring module SafetyBox
0211-155	Power supply cable, 230 V, 5 m long

Additional accessories when using a compressed air motor

Ref.-No.	Description
0211-151	Connecting cable SLOW valve, 5 m long, 230 V, 50 Hz
5000-167	2/2-way solenoid valve blocks the air supply to the drive motor, Brass G 3/8 IT



Lutz Pumpen GmbH

Erlenstraße 5-7
D-97877 Wertheim
Phone: +49 93 42 / 8 79-0
Fax: +49 93 42 / 87 94 04
E-Mail: info@lutz-pumpen.de

www.lutz-pumpen.de